

WO!skimmer

NQ-60

INSTALLATION GUIDE

Thank you for purchasing our new WO!skimmer that provides optimum performance with maximum safety and reliability.

Model	NQ-50	NQ-60	NQ-80
Size (mm)	100*65*280	120*85*330	180*90*420
Reaction Chamber	40mm	60mm	80mm
Outlet	16mm	20mm	25mm
Max.Flow Rate	500L/H	730L/H	1100L/H
Max.Air Intake	100L/H	150L/H	250L/H
Max.Tank Size	90L	120L	200L
Place for Installation	Interior/sump	Interior/sump	Interior/sump
Pump	6W	9W	15W

Importance

Prior to the installation, please read the manual and the following proper operation instruction carefully:

- Assemble parts and components according to the illustration.
- Do not move the skimmer when it is working, otherwise it will cause permanent damage.
- It would not be better let the skimmer work in the water temperature above 35 degrees or below freezing point, otherwise it will cause some damage.
- When the skimmer is working, make sure voltage and frequency in accordance with the specified instruction.

Part Names

- A.** Lid for collection cup
- B.** Collection cup
- C.** Rotation Type Water Level Adjustor
- D.** Diversion Box
- E.** Water Pump
- F.** Noise Silencer
- G.** Air Intake Tube
- H.** Air Filling Part

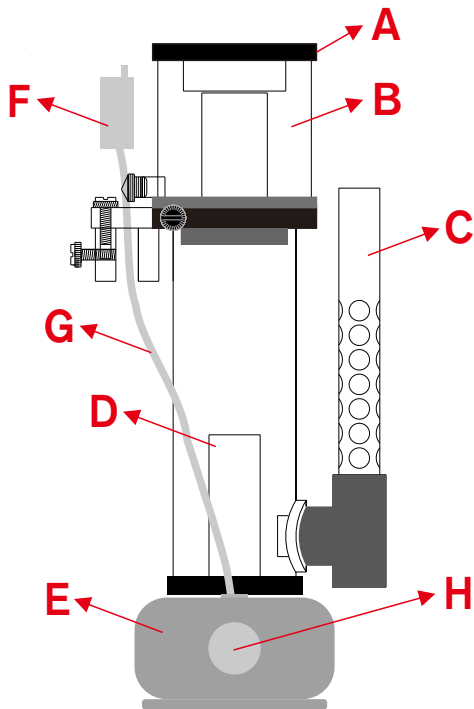

Maintenance

- Collection cup needs to clean regularly to remove precipitation and impurities.
- Reaction Chamber do not need to clean, unless there is some impurity stick to the wall.
- If the device can not work normally, please check the following details:
 - A.** Check whether socket and plug is well connected or there is power supply.
 - B.** Check if there is any impurity blocking noise silencer, air intake tube or air filling part when there is less or no bubbles while working.
 - C.** Since rotor or impeller maybe blocked and damage by sands or impurities, the water pump installation should be carried out in no sands and impurities.



WOTEWO AQUARIUM SUPPLIES
E-mail: info@wotewo.com
[Http://www.wotewo.com](http://www.wotewo.com)